



ROYAL COLLEGE OF ARTS, SCIENCE & COMMERCE

Empowerment through Value Education

Mira Road, Dist. Thane – 401 107

Autonomous

Affiliated to University of Mumbai

Reaccredited 'A' Grade by NAAC (3rd cycle)

Best College Award (University of Mumbai)

'One District One Green Champion' Award (MGNCRE)

Prospectus 2024-2025

Ismail M. Kanga Educational Campus Comprising

- Fazalehusein Zaveri College of Arts
- Adamally Adenwala College of Science
- Sugra-Asma College of Commerce
- Camaruddin G. Poonawalla Junior College

1



Prof. A. E. Lakdawala
The Founder

College Campus





राष्ट्रीय मूल्यांकन एवं प्रत्यायन परिषद

विश्वविद्यालय अनुदान आयोग का स्वायत्त संस्थान

NATIONAL ASSESSMENT AND ACCREDITATION COUNCIL

An Autonomous Institution of the University Grants Commission

Certificate of Accreditation

*The Executive Committee of the
National Assessment and Accreditation Council
on the recommendation of the duly appointed
Peer Team is pleased to declare the
Royal College of Arts, Science and Commerce
Penkar Pada, Dist. Thane, affiliated to University of Mumbai,
Maharashtra as*

Accredited

with CGPA of 3.09 on four point scale

at A grade

valid up to September 08, 2024

Date : September 09, 2019



*S. C. Sharma
Director*

BEST COLLEGE AWARD





ROYAL COLLEGE OF ARTS, SCIENCE & COMMERCE

Empowerment through Value Education

Re-Accredited 'A' Grade by NAAC (3rd Cycle)



Congratulations to **Royal College Student** **RAMAKISHAN THORI**

For receiving **GOLD MEDAL** from
Vice-Chancellor, University of Mumbai

at the **Convocation Ceremony**

held on **7th Feb. 2024** For

Securing Highest marks

in **Physics** Subject amongst

All the students of University at

T.Y.B.Sc. Examination

held in April 2023





ROYAL COLLEGE OF ARTS, SCIENCE & COMMERCE

Empowerment through Value Education

Re-Accredited 'A' Grade by NAAC (3rd Cycle)



Congratulations to all Stakeholders
our college is recognized as

District Green Champion

of Thane District &
We have been awarded

One District One Green Champion Award by

Mahatma Gandhi National Council of Rural Education
Ministry Of Education, Government Of India

at Virtual Function held on 12th August 2021, Award presented by

Thane District Collector Shri. Rajesh Narvekar



AWARD CRITERIA
IMPLEMENTATION OF BEST PRACTICES IN THE AREAS OF

- CLEANLINESS
- SANITATION
- HYGIENE
- WASTE MANAGEMENT
- WATER CONSERVATION
- ENERGY CONSERVATION
- GREENERY MANAGEMENT

We shall strive hard to continue our legacy of Clean & Green College Campus

A Brief History of Royal Society of Bombay

The society was founded on **28th December, 1966** by **Asgar E. Lakdawala** while he was an SSC student. He gathered together a very small group of young boys with a spirit of service, will to sacrifice, and most importantly a readiness to share his vision of the educational upliftment of the poor and needy children of the Bohra community. Being from poor backgrounds themselves, they shared a bond of friendship and understanding which soon became rooted in purpose. Guided by the mission of their Founder, they soon set out to lead in the field of Education. Since 1966, more and more benefactors from the Bohra community realized the importance of the mission. Today, there are about 600 life members & patron members. The Society primarily aims at the education of the Bohra & non-Bohra Muslim community & extends its facilities to other communities as well.



Action So Far

Since its inception, the society has strived to provide at least the **basic needs of education** so that the **underprivileged** section of the society can **avail good education** without making it an extra burden on the day to day expenses of their parents. Every year, about **3000 needy students** are benefited by the various schemes which include:

- **School Fees, College Fees, Books & Stationery to the poor students from pre-primary to higher education.**
- **Royal Educational Adoption Plan (REAP) under which needy and bright students are adopted and given financial aid to acquire their desired goal.**
- **Medical aid to needy.**

About the College

In the year 1986, while at Elphinstone College as a lecturer, Prof. Asgar E. Lakdawala - Founder of this Royal Campus - dreamt of establishing a full-fledged Arts, Science and Commerce College. To turn his dream into reality, he, along with like-minded co-workers had no alternative but to run from pillar to post requesting the generous contributions from philanthropists of the Bohra Community. The philanthropists trusted the sincerity of his intentions and the absolute zeal with which he worked towards his mission and decided to extend full financial support which helped him establish this College in 1989.

Royal College is a **Muslim Minority Institution** which aims at uplifting the educational standards of the Muslim community and extends its facilities and services to other communities as well. The plot of land admeasuring around 10,000 square meters, where the college building stands at present, was generously donated by Late Ismail M. Kanga, the then Chairman of Srishti Housing Complex

Royal Society of Bombay with the help of its generous philanthropists from the Bohra community, has spent more than ₹18 crores to give the institution and its campus its present shape.

WE HAVE NEARLY 100% RESULTS SINCE INCEPTION.

VISION

To be **recognized as a Minority Institution** par excellence **with a secular perspective** imparting value based education to create socially responsible, eco-conscious, disciplined citizens empowered to participate and contribute to the economic and cultural growth of the Nation.

MISSION

- To provide holistic academic programmes to nurture **personal, professional and social** growth of students
- To promote education for minority community with emphasis on **Girls' education** and extend the same **to other communities.**
- To Provide an inspiring teaching learning environment to realize **intellectual potential** and **foster global competencies.**
- To inculcate **Ethical, Moral** and Environmental Values amongst students

OBJECTIVES

- To adopt **innovative and technology** driven pedagogical methods
- To inculcate **scientific temper** and **spirit of inquiry**
- To impart **special skills** and **practical knowledge**
- To hone **students' creativity** and **potential**
- To promote **sports** and **healthy living**
- To instill **civic, social** and **ecological responsibility**
- To make **learning** a **joyful** experience

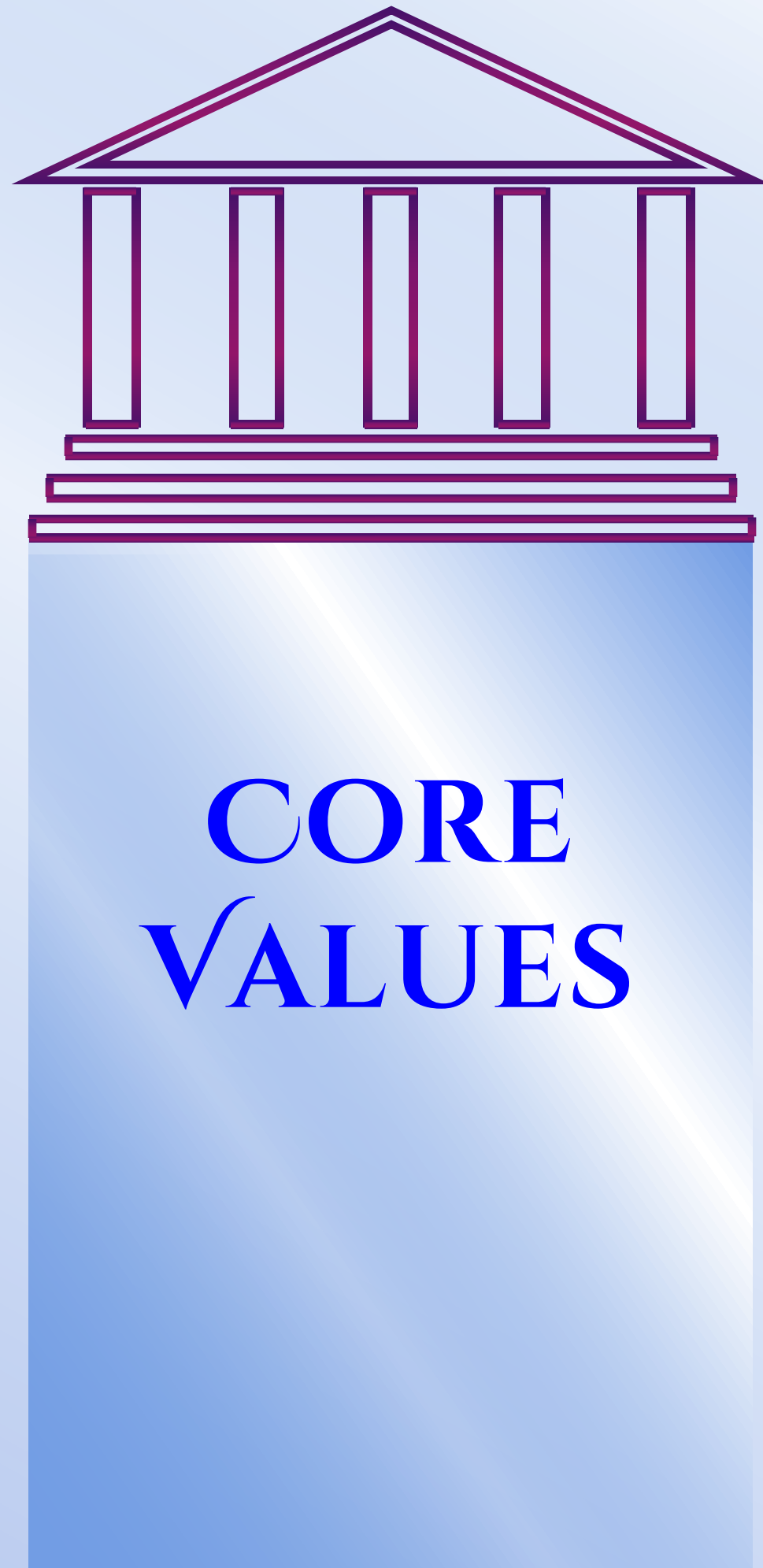

- To pursue excellence in teaching, learning, research and administration through rigorous process of self evaluation, accountability and continuous improvement.
- To infuse a strong value system with emphasis on Integrity, Equality, Honesty, Perseverance, Discipline, Respect for all, Ethics and Service to Society and Nation.
- To develop Scientific temper and professional competency amongst students by imparting research orientation, special skills and contemporary knowledge.
- To instill a sense of civic, social, ecological and professional responsibility in students to ensure holistic growth and participation in National Development.
- To promote the use of innovative and technology driven methods in all spheres of institutional functioning.

D**ETAILS**

1) TERMS FOR 2024 - 2025

The details will be available on the college website after we get the details from the University of Mumbai and Deputy Director of Education.

2) COLLEGE OFFICE

- The office is located on the Ground floor of the college building.
- The regular office timings are from 9.30 a.m. to 12.30 p.m. - Monday to Friday.
- Students may correspond via email and phone also.
- Students may contact the Superintendent in case of any difficulty

3) RULES FOR ADMISSION

- I) Right of admission is reserved by the Management.
- II) Students who have passed their S.S.C. or equivalent examination privately will not be admitted to this College.
- III) Detailed notice regarding admission will be available on college website.
- IV) All admissions are valid only for one academic year and are **required to be renewed by application** in the prescribed form every subsequent year of study in the college.
- V) Once a student is admitted to the college, he/ she shall be liable to pay fees as prescribed
- VI) **Undertaking:** All students are expected to conduct themselves in a manner worthy of being a member of the College community. Such conduct is based on respect for the dignity and rights of individuals, respect for public and personal property, and personal and academic honesty. The behaviour of students outside the campus also affects the prestige of the institution and hence will be taken note of.
At the time of admission, every student shall **sign a declaration**, on his/her admission form, that he/she will abide by all rules and regulations and accept the decision of the Principal/Management, in all matters, as final.
- VII) **Ragging is strictly prohibited in the college premises and outside.** Students indulging in ragging will be punished as per "UGC Regulation on Curbing the menace of ragging in, higher educational institution, 2009". Such students will also be expelled from the college and F.I.R. will be lodged with the police against them. Moreover, it will be mentioned in the college leaving certificate of such students that they are expelled because of their indulgence in ragging.

As per the UGC regulations, all degree college students and parents are required to submit an online undertaking of anti-ragging, every academic year at www.antiragging.in & www.amanmovement.org

4) CODE OF CONDUCT

- Students shall abide by all the rules and regulations laid down by the college authorities.
- Students must put in a minimum attendance of 75% in each term failing which they shall not be allowed to appear for the Term/ Semester/ Final Examination.
- Students shall not remain absent for lectures, practicals and tutorials without valid reason.
- They are expected to keep their guardians informed about the progress of their studies and other matters while studying in the college.
- Parents of Degree / Junior college students are requested to contact the Vice Principal or Guardian teacher or the Principal at least once in a term to keep themselves informed about their wards' attendance & progress. Whenever they are called by the college authorities, they shall make it a point to come and meet them in the interest & welfare of their wards.
- It is presumed that guardians are acquainted with and agree to abide by the rules of the college when their wards take admission in the college.
- Students are expected to READ THE NOTICE BOARD DAILY so that they are abreast of curricular, co-curricular & extra curricular activities announced in the college & the dates of different activities. No concession will be given for any matter whatsoever on the ground of ignorance due to their failure to read the notices.

- Students are expected to take proper care of the College property and co-operate in keeping the premises clean and tidy. Any damage to the College building or property by disfiguring walls, benches, doors or breaking furniture, projectors, fittings etc. is a breach of discipline and will be strictly dealt with.
- Transcripts: Students desirous of pursuing further studies abroad should apply for transcripts along with necessary fees to the Transcript counter well in advance during office hours. After verification of marksheets and other relevant papers, the college will hand over the transcripts/Recommendation Letter.
- Dress Code: Students must come to College suitably dressed, that is, in dress appropriate to an Educational Institution.

The College offers a very¹⁵ safe and secured environment with close circuit cameras installed at all strategic places .

5) IDENTITY CARD

A student on admission to the college has to keep with him/ her an identity card (issued by the college office bearing his/her name, Roll No., Class, Division and his / her photograph duly attested by the Principal. Entry to college premises, lectures, practicals, college functions or access to the library, college office, laboratories and canteen is strictly through a valid **identity card which must be worn throughout the stay in the college premises.**

Student should apply for a **duplicate I-card** if it is soiled, spoiled, or lost.

No student will be allowed to appear for any college or University examination unless he/she possesses the valid identity card/ Hall Ticket.

6) YUVA RAKSHA INSURANCE POLICY FOR STUDENTS

In the event of any accident claim, the students are required to submit the documents in original to the insurance company through college provided the parents bring in to the notice of the college within 3 days of any minor/major accident resulting in hospitalization. The premium to be paid by the student is ₹25/- per annum to cover the insurance scheme of ₹1 lakh. The college authorities will forward the above mentioned documents to the insurance company. For further details, the students should contact the college office.

16

7) MEDICAL FACILITY

The college has a tie-up with the Bhakti Vedant Hospital to provide immediate medical attention to the Bonafide students and staff members of the college in case of an accident, mishap or any kind of emergency that may take place on campus. When such an incident is reported to the college authorities, they will facilitate the admission of student/ staff member to the hospital for immediate medical attention, without undergoing the normal procedure of cash deposit in the hospital. The cost of treatment for students and staff members of that particular day is borne by the college.

8) INFORMATION ABOUT GOVERNMENT SCHOLARSHIP / FREESHIP

Sr. No.	Name of the Scholarship / Freeship	Eligibility
1	Government of India Scholarship (SC / ST / NT / VJ / OBC / SBC)	Annual income not more than ₹. 1,00,000/- (For NT / VJ / OBC / SBC) ₹. 2,00,000/- (For SC/ST).
2	State Government Open Merit Scholarship	More than 60% marks at H.S.C. Examination
3	Physically Handicapped Scholarship	1. Physically handicapped having a certificate (Minimum 40%) by the Civil Surgeon. 2. Minimum 40% marks in last examination
4	Scholarship for the Ex-Servicemen's Sons / Daughters /Wife / Widow	Sons / daughters / wife / widow of Ex-serviceman
5	Post Matric Scholarship of Minority Community (Muslim, Sikh, Christian, Buddhist and Parsi)	1. The minority students who have secured not less than 50% marks or equivalent grade in the final examination 2. The annual income of parent's /guardians from all sources does not exceed ₹. 2,00,000/-
6	Government of India Freeship (SC / ST / NT/ OBC / SBC)	1. Annual income more than ₹.2,00,000/- for SC/ST students. 2. Annual income more than ₹.1,00,000/- for NT / VJ / OBC / SBC learners.
7	Scholarship for Physics and Mathematics Subject	More than 60% marks in Physics or Mathematics subject at H.S.C examination and to study this subject up to degree level.
8	Rajarshri Chhatrapati Shahu Maharaj Shikshan Shiksha Shishyavrutti Yojna	The annual income should not be more than ₹.8,00,000/- per annum.
9	State Minority Scholarship Muslim, Sikh, Christian, Buddhist and Parsi)	The annual income should not be more than ₹.8,00,000/- per annum.
10	Begum Hazrat Mahal national scholarship For meritorious girl students belonging to the minority communities	The annual income should not be more than ₹.2,00,000/- per annum.
11	Central sector scheme of scholarships for college and university students	Students who are above 80th percentile of successful candidates in the relevant stream from the respective Board of Examination in Class XII of 10+2 pattern or equivalent The annual income should not be more than ₹.4,50,000/- per annum.

In addition to the above scholarship, students can visit National Scholarship portal scholarships.gov.in or Government of Maharashtra Scholarship portal mahadbtmahait.gov.in for details of many other scholarships schemes.

Parents Income Certificate / Utpannacha Dakhala from Tahsildar Office is required to apply for all the above scholarships. Students are advised to check the scholarship notice board regarding details of various scholarships from time to time. Students can contact the Administrative Office during office hours (9.30 a.m. to 12.30 p.m.) for guidance or any query related to different scholarships mentioned above.

9) NEEDY STUDENT SCHOLARSHIP INSTITUTED BY ROYAL HIGHER EDUCATION SOCIETY

Scholarship of ₹5000/- each will be given to 5 needy students studying in S.Y. / T.Y. degree class and ₹3000/- each will be given to 5 needy students studying in XII Arts / Science / Commerce class.

LIST OF NEEDY STUDENT SCHOLARSHIP

1	Camaruddin G. Poonawalla Scholarship ₹5000/-	6	Mrs. Zubeda C. Poonawalla Scholarship ₹3000/-
2	Hussain Adamally Scholarship ₹5000/-	7	Abbas M. Tata Scholarship ₹3000/-
3	Ismail M. Kanga Scholarship ₹5000/-	8	Faizullahbai Tapia Scholarship ₹3000/-
4	Taher Adamally Scholarship ₹5000/-	9	Late Mohammed Taherally Bandukwala Scholarship ₹3000/-
5	Yousuf Fazalehusain Zaveri Scholarship ₹5000/-	10	Nakhoda Scholarship ₹3000/-

Statutory Bodies

MINORITY CELL

The minority cell provides services to the educational and cultural needs of the Minority community along with other caste, creed and Nationality. The Minority Cell basically helps minority students including Christian, Muslim, Jain, Buddhists etc. for their academic development.

OBJECTIVES:

19

- To ensure an environment that supports the diversity of religious and cultural beliefs of minorities
- To encourage the academic upliftment of minorities
- To educate the stakeholders of the various scholarship schemes for minorities available under central & state government
- To identify & counsel financially challenged minority students
- To ensure compliance with the reservation policies as applicable to minority institution

ANTI-RAGGING CELL

Pursuant to the circular issued by UGC on the subject of "Curbing the menace of Ragging in HEIs", Anti Ragging cell was constituted in the year 2017.

SC/ ST/ OBC CELL

The Cell organizes informal meetings with students to attend to their personal, social and academic problems.

OBJECTIVES:

- To collect data regarding the implementation of the policies in respect of admission and scholarships.
- To implement, monitor and evaluate continuously the reservation policy in college plan, measures for ensuring effective implementation of the policy and programme of the Government of India.

INTERNAL COMPLAINT COMMITTEE (ICC) & PREVENTION OF SEXUAL HARASSMENT CELL

The Sexual Harassment of Women at workplace (Prevention, Prohibition and Redressal) Act, 2013 was passed by the Parliament of India. The Act provides protection against Sexual Harassment of Women at Workplace and for the prevention and redressal of complaints of sexual harassment and for the matters connected thereof with or incidental there to.

OBJECTIVES:

1. To take consistent action for prevention, prohibition and redressal of complaints received regarding sexual harassment and gender discrimination of women personnel at the workplace.
2. Make recommendations to the Management to lay down procedures for the prohibition, resolution, settlement, and prosecution of acts of discrimination and sexual harassment, by the students and the employees
3. Deal with cases of discrimination and sexual harassment against women, in a time bound manner, aiming at ensuring support services to the victimized and termination of the harassment.
4. Recommend to the Management about the appropriate punitive action against the guilty party. The Internal Complaint Committee (ICC) of the College was constituted in June 2017 in accordance with The Sexual Harassment at Workplace (Prevention, Prohibition and Redressal) Act, 2013.

WOMEN DEVELOPMENT CELL

The college Women Development Cell was established in the year 2005 as per university directives, with a perspective that arises out of an understanding of gender equality in its entire ramification. All the activities are oriented towards gender sensitization, women empowerment, and awareness. Accordingly, various literary and performing activities like essay writing, poster making, street plays, skits, debate, and guest talks are organized round the year. We have also constituted a Legal Cell for guidance

JUNIOR COLLEGE



FOR F. Y. J . C. CLASS UNDER MINORITY QUOTA

- Since ours is a Religious Minority Institution, 50 percent of the seats in each stream are reserved for the Muslim Minority students.
 - Pre-application forms for these are to be filled up and the selection will be strictly on the basis of merit.
 - Muslim minority students should fill up the pre-application form within the stipulated time. Details regarding pre-application forms will be put up on the college notice board and college website.
 - Muslim minority students should also fill up the pre-application form as per the procedure laid down by the Deputy Director's Office. Students should give the option for other Colleges along with our College to avoid disappointment if they do not get admission under minority quota at our College. Copy of online registration with Deputy Director's office will have to be submitted by the student.
- 10 percent of the seats are reserved for our in-house school students

F. Y. J . C. ONLINE ADMISSION

While taking admission to F.Y.J.C Class, student shall submit the following documents ONLINE:

- Duly filled in admission form with scanned passport size colour photograph.
This photograph will be used for Identity Card also.
- Copy of SSC marksheet.
- Copy of School Leaving Certificate or Transfer Certificate.

DETAILED NOTICE REGARDING ADMISSION PROCEDURE WILL BE PUT UP ON THE WEBSITE AND COLLEGE NOTICE BOARD.

STUDENTS COMING FROM OTHER STATES (JUNIOR COLLEGE)

24

Eligibility procedure for students coming from other states or those who have taken examinations other than that of the Maharashtra State Board will be done by the College later on, after the College reopens. Students will have to submit all the documents required at that time only, failing which College will not be responsible for eligibility confirmation.

NOTE: ADHERING TO THE RULES OF THE MAHARASHTRA BOARD, THE CLASS XI RESULTS OF THOSE STUDENTS WHO DO NOT FULFILL THE ELIGIBILITY CRITERIA WILL NOT BE DECLARED.

F.Y.J.C. & S.Y.J.C.(ARTS)

A) COMPULSORY SUBJECTS

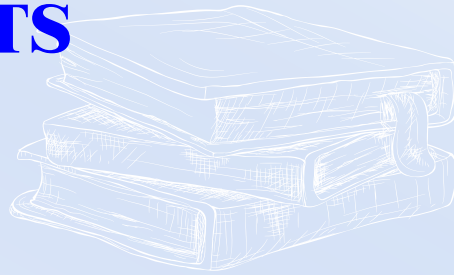

- a) English
- b) Economics
- c) Political Science
- d) Sociology
- e) Environment Education and Water Security
- f) Health & Physical Education

B) OPTIONAL SUBJECTS

Select Any one of the following combination

- a) Hindi-History
- b) French-History
- c) Hindi - Urdu
- d) Hindi - Psychology
- e) French - Psychology
- f) Urdu - Psychology
- g) Urdu - History

F.Y.J.C. & S.Y.J.C. (SCIENCE)

GENERAL SCIENCE

A) COMPULSORY SUBJECTS

- a) English
- b) Mathematics & Statistics
- c) Physics
- d) Chemistry
- e) Environment Education and Water Security
- f) Health & Physical Education

B) OPTIONAL SUBJECTS

1) Select Any One Language

- a) Hindi b) French c) Urdu

2) Biology or Economics

For S.Y.J.C. Class, Student can select Mathematics OR Economics

F.Y.J.C. & S.Y.J.C (COMMERCE)

A) COMPULSORY SUBJECTS



- a) English
- b) Economics
- c) Mathematics & Statistics
- d) Organisation of Commerce
- e) Book-Keeping & Accountancy
- f) Environment Education and Water Security
- g) Health & Physical Education

B) OPTIONAL SUBJECTS

Select Any one

- a) Hindi b) Urdu c) French
- d) Information Technology
(Information Technology seats are given on the basis of merit only.)

For S.Y.J.C. Class, Student can select Mathematics OR Secretarial Practice

COMPUTER SCIENCE

- a) English
- b) Mathematics & Statistics
- c) Physics
- d) Chemistry
- e) Environment Education and Water Security
- f) Health & Physical Education
- g) Computer Science - I
- h) Computer Science - II



Note:

- For **Environment Education and Water Security**, out of 50 marks 30 marks are assigned for project work to be done individually by the student and remaining 20 marks will be given for Journal Assignments. Total marks will be converted into grades.
- For **Health and Physical Education**, theory examination as well as practical examination will be conducted and total marks will be converted into grades.
- Students obtaining D grade in Environment Education and Water Security or D grade in Health and Physical Education will be declared as fail by the college / Maharashtra State Board of Secondary and Higher Secondary Education even if the student is passing in all other subjects.

F.Y. J .C. (ARTS, SCIENCE, COMMERCE) EXAMINATION SYSTEM AND PROMOTION TO S.Y. J .C. CLASS

SR. NO.	NAME OF THE EXAMINATION	MAXIMUM MARKS IN EACH SUBJECT	SYLLABUS FOR EXAMINATION
1.	First Unit Test	25	Portion taught till last working day before this examination.
2.	First Semester Exam	50	Entire portion of the first term.
3.	Second Unit Test	25	Second term Portion till last working day before this examination.
4.	Annual Examination	100	Entire syllabus of F.Y.J.C. class.

- Promotion to S.Y.J.C. Class will be on the basis of Average Marks of all the four examinations.
- There will be OPEN HOUSE for the parents of **F.Y.J.C.** students after first unit test as well as after First Semester Examination. Details about date and timings will be communicated to parents through written letters after the respective examination is over.
- Corrected answer papers of all the Subjects for all the examinations (except Annual Examination) are given to students.

DEGREE COLLEGE



NEP-2020

The National Education Policy (NEP) 2020 outlines a transformative vision for India's education system. It focuses on empowering students through a multidisciplinary, flexible, and holistic approach to learning and assessment.



FEATURES OF NEP-2020

1. **Multidisciplinary Education:** encourages multidisciplinary learning where students can choose a combination of subjects across disciplines, leading to a more holistic learning experience.
2. **Flexibility:** It emphasizes flexibility in course structures, allowing students to choose from a wide range of elective subjects.
3. **Assessment Reforms:** Shift from rote learning to competency-based assessment methods to evaluate holistic development and application of knowledge.
4. **Integration of Vocational Education:** NEP 2020 emphasizes the integration of vocational education and skill development into the higher education system. It aims to bridge the gap between academic learning and practical skills required for employment.

FRAMEWORK OF THE NEP CREDIT SYSTEM

Major (Core) Subject



It is the main discipline or subject and the degree will be awarded in that discipline/ Subject. Students should secure a minimum 50% of total credits through Core Courses

Minor Subject:



A second subject of study pursued by a student as an additional requirement of the programme of study.

Vocational Skill Course (VSC) and Skill Enhancement Course (SEC):

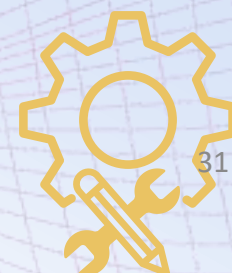

Courses which are aimed at imparting practical skills, nurturing soft skills etc., to enhance the employability of students. To be selected from the basket of Vocational Courses and Skill Courses related to the major course.

Open Elective (OE):



Course that students can choose from a basket of options from a faculty different from their primary discipline or area of study.

FRAMEWORK OF THE NEP CREDIT SYSTEM

Ability Enhancement Courses (AEC):



A course designed to improve linguistic and communication skills of the students. It contains English and any other Indian language as a subject of study.

Value Education Courses (VEC):



A course based on topics such as Understanding India, Environmental Science/ Education, and Digital and Technological Solutions.

Indian Knowledge System (IKS):



A course designed to study the rich and diverse knowledge traditions and systems that have evolved over centuries in India. It is integrated into the education system to promote a deeper understanding of India's cultural heritage, scientific achievements, and traditional wisdom.

Co-curricular courses (CC):



Co-curricular activities contribute to the overall growth and well-being of students, preparing them for a successful future. Co-curricular Courses (CC) includes Health and Wellness, Yoga education sports, and fitness, Cultural Activities, NSS/NCC and Fine/ Applied/Visual/ Performing Arts

Note: All these courses will be finalized at the time of admission

Faculty of Arts

NEP Credit Structure for Arts

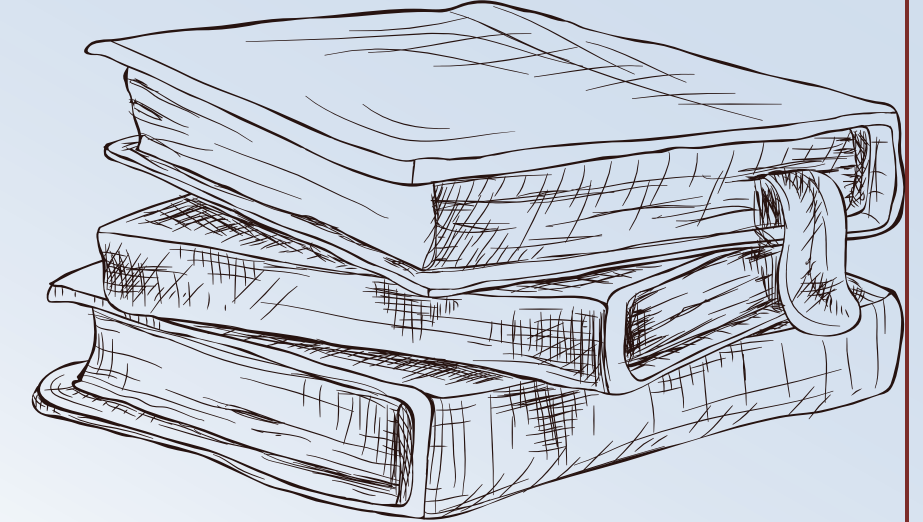

Level	Sem	Subject 1	Subject 2	OE	VSC	SEC	AEC	IKS	VEC	OJT/FP /RP/CC /CEP	Cumulative Credits	
		DSC	DSE									
4.5	I	4	4	4		2	2	2	2	2	22	UG Certificate Cumulative Credit:44
	II	4	4	4		2	2		2	4	22	
Exit Option: Award of UG Certificate in Major with 40 -44 Credits and an Additional 4 Credits Core NSQF Course / Internship OR Continue with Major and Minor												
5	III	8	4	2	2	2	2			2	22	UG Diploma Cumulative Credit:88
	IV	8	4	2	2	2	2			2	22	
Exit Option: Award of UG Diploma in Major and Minor with 80-88 Credits and an Additional 4 Credits Core NSQF Course / Internship OR Continue with Major and Minor												
5.5	V	12	4	2		2				2	22	UG Degree Cumulative Credit:132
	VI	12	4	2		2				2	22	
	Total	48	8	20	12	8	8	8	2	4	14	132

Faculty of Arts

FYBA

Subject Combinations

Sociology Economics

Sociology Psychology

Sociology Hindi

³⁴
Political Science Hindi

Political Science Economics

Political Science Psychology

(Students are required to select any one of the above subject combination)

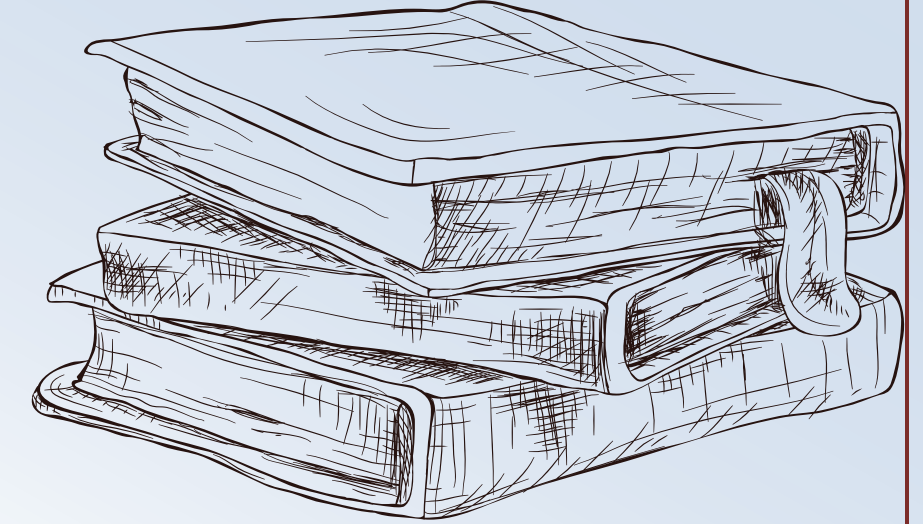

Faculty of Arts

FYBA

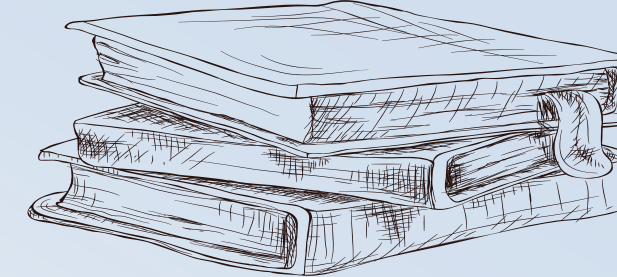

Vocational Skill Course and Skill Enhancement Course

Open Elective Course

Department	Semester I	Semester II
Sociology	Introduction to Social Work	Cultivating Sociological Sensibility
Political Science	Introduction to Social Work	Legal Literacy- Rights Awareness
Economics	Entrepreneurship and Business Innovation in Economics-I	Money Management-I
Psychology	Application of Behavior Modification in Educational Setting	Introduction to Effective Academic Planning and Time Management

Semester I	Semester II
Basics of HRM – I	Basics of HRM – II
Financial Literacy	Indian Financial Systems
E-Commerce and Digital Marketing	Cyber law and IPR – I
Web Designing	Auditing
Data Analytics using excel	IT Platforms tools and practices
Chemistry in everyday life – Food Chemistry	Structured Query Language
Descriptive statistics I	Chemistry in everyday life – Chemistry of Cosmetics and Grooming Products
Nursery development and Garden operation	Descriptive statistics II
	Mushroom cultivation

BACHELOR OF ARTS

PROGRAMME OUTCOMES (POs):

On successful completion of B.A. programme students are anticipated to:

- Manifest comprehensive understanding of concepts of the core and elective papers
- Demonstrate scientific temperament when faced with varied world views.
- Develop employability and an ability to apply theory into practice in real-life situation.
- Demonstrate tolerance and sensitivity in social interactions in a multicultural and digital world.
- Demonstrate ethical ideals and academic responsibility.

BACHELOR OF ARTS (SOCIOLOGY)

PROGRAMME SPECIFIC OUTCOMES (PSOs): On successful completion of the BA in sociology program, students are expected to:

- Work with independence, self-reflection and creativity to meet goals and challenges at workplace and in personal life.
- Act as informed and critically discerning participants within the community, as citizens and in the work force.
- Recognize the role of an individual within community to effect change.
- Pursue higher education and take up employment.
- Develop a "sociological imagination" and apply a sociological perspective to experiences, tasks and activities in real life situation.

BACHELOR OF ARTS (POLITICAL SCIENCE)

PROGRAMME SPECIFIC OUTCOMES (PSOs): Towards the end of the program, the students are expected to imbue with following qualities

- Able to classify and compare specific characteristics of Indian politics using social science and political science theories and concepts.
- Able to think critically about their own political values, positions, and informed political choices of citizens, advocates and leaders.
- Able to analyze and evaluate claims made about Indian politics using theoretical and empirical knowledge from the social sciences.
- Able to evaluate changing social and political situation in India and in the world.
- Develop interdisciplinary and comprehensive understanding among the students about political reality.
- Pursue higher education and employment.

BACHELOR OF ARTS (ECONOMICS)

PROGRAMME SPECIFIC OUTCOMES (PSOs): On completion of B.A. in Economics students are expected to:

- Understand and apply in real world core-microeconomics and macroeconomics concepts and theories.
- Identify key economic problems and cyclical fluctuations³⁷ affecting the economy and measures to be taken to safeguard individual financial position.
- Analyse the effect of monetary or fiscal strategy and its desired outcome on the economy.
- Differentiate between economic growth and economic development and factors responsible to achieve the same.
- Functioning of the economy and decide whether measures taken by the Government are correct to improve the condition of Indian economy.
- Achieve economic growth with sustainable development

BACHELOR OF ARTS (PSYCHOLOGY)

PROGRAMME SPECIFIC OUTCOMES (PSOs): On successful completion of B.A. in Psychology students are expected to:

- Demonstrate an understanding of psychological concepts and theories.
- Demonstrate scientific temperament in understanding the application of psychology in real context.
- Act as an ambassador of mental health promotion in society.

BACHELOR OF ARTS (HINDI)

PROGRAMME SPECIFIC OUTCOMES (PSOs): On completion of B.A. in Hindi students are expected to :

- Improve writing and communication skills.
- Comprehend the foundations, process and practices of writing for and about the media.
- Understand the cultures and traditions of ancient India through literature.
- Enhance their confidence in debating by making them outspoken towards the current affairs.
- Integrate Information technology with Hindi to enable its use in banking, journalism, e-governance, etc

Faculty of Science

NEP Credit Structure for Science

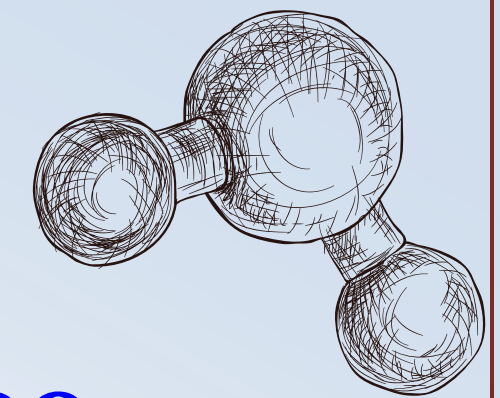

Level	Sem	Major		Minor	OE	VSC	SEC	AEC	IKS	VEC	OJT/FP /RP/CC /CEP	Cumulative Credits	
4.5	I	DSC 6	DSE	6	2		2	2	2	2		22	UG Certificate Cumulative Credit:44
	II	6		6	2	2		2		2	2	22	
Exit Option: Award of UG Certificate in Major with 40 -44 Credits and an Additional 4 Credits Core NSQF Course / Internship OR Continue with Major and Minor													
5	III	8		4	2+2	<small>39</small>	2	2			2	22	UG Diploma Cumulative Credit:88
	IV	8		4	2+2		2	2			2	22	
Exit Option: Award of UG Diploma in Major and Minor with 80-88 Credits and an Additional 4 Credits Core NSQF Course / Internship OR Continue with Major and Minor													
5.5	V	10	4			4					4	22	UG Degree Cumulative Credit:132
	VI	10	4			4					4	22	
Total		48	8	20	12	10	6	8	2	4	14	132	

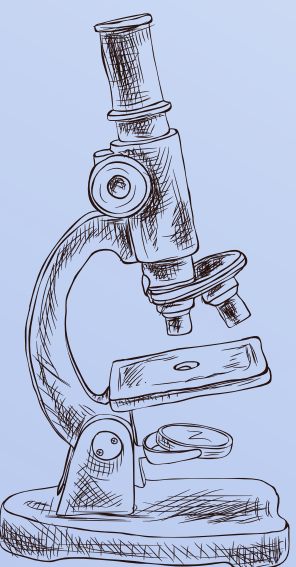

Faculty of Science

FYBSc

Subject Combinations

Physics-Chemistry

Physics-Mathematics

Chemistry-Zoology

Chemistry-Microbiology

Chemistry-Botany

(Students are required to select any one of the above subject combination)

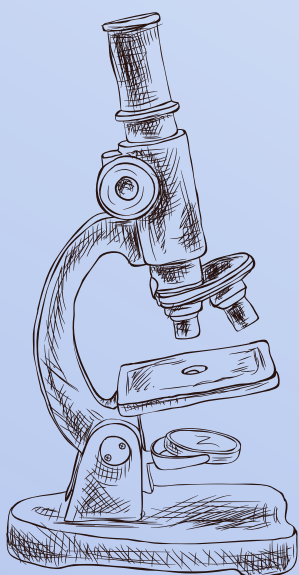
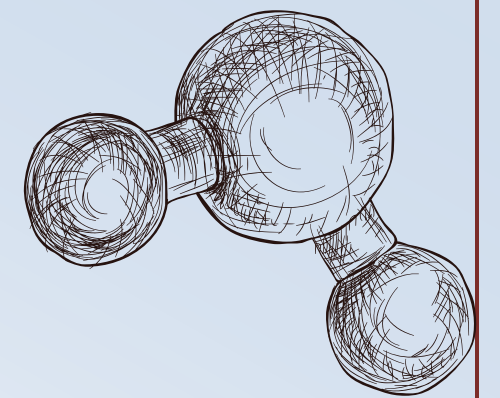

Faculty of Science

FYBSc

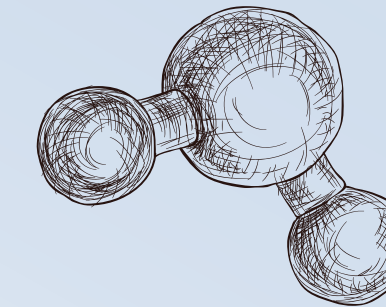

Vocational Skill Course and Skill Enhancement Course

Department	Semester I	Semester II
Chemistry	Lab Safety , Preparation and standardization of solutions	Introduction to Instrumental Methods
Physics	Measuring Instruments	Digital Electronics
Microbiology	Tools and Techniques in Microbiology	Tools and Techniques in Microbiology II ⁴¹
Maths	Numerical methods	Ordinary Differential Equations
Zoology	Laboratory safety, Units and measurement. Biostatistics	Instrumentation
Botany	Ethnobotany	Flower arrangement and Food Processing

Open Elective Course

Semester I	Semester II
Basics of HRM – I	Basics of HRM – II
Financial Literacy	Indian Financial Systems
E-Commerce and Digital Marketing	Auditing – I
Know your Society (I)	Cyber law and IPR – I
Short Film Making & Editing Course	Welfare State and Society (II)
Personal Effectiveness I	The Art of Reel Making
	Personal Effectiveness II

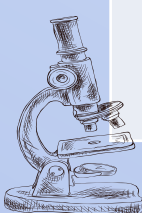

BACHELOR OF SCIENCE

PROGRAMME OUTCOMES (POs): As a graduate of Science faculty a student should have:

- Acquired the basic knowledge related to the subject offered.
- Understood the basic concepts, fundamental principles, and the Scientific theories related to various Scientific phenomena and their relevance in day-to-day life.
- Acquired the skills in handling Scientific instruments.
- Acquired the skills of planning and performing laboratory experiments, recording observations and drawing logical inferences from the Scientific experiments.
- Developed Scientific outlook not only with respect to Science subjects but also in all aspects related to life.

BACHELOR OF SCIENCE (CHEMISTRY)

PROGRAMME SPECIFIC OUTCOMES (PSOs): By the end of the programme, graduates will be able to:

- Have a spirit of inquiry into the fundamental aspects of the various core areas of Chemistry.
- Analyze the various observations and chemical phenomena presented to him during the course.
- Solve problems in the various units of this course.
- Get hands on experience of the concepts and processes in the various branches of Chemistry.
- Get various skills of handling chemicals, reagents, apparatus, instruments and the care and safety aspects involved in such handling.
- Analyze and interpret results of the experiments he/she conducts or performs.
- Acquire or pursue a source of livelihood like jobs in Chemical industry.
- Arouse the interest to pursue higher levels of learning in Chemistry.

BACHELOR OF SCIENCE (MICROBIOLOGY)

PROGRAMME SPECIFIC OUTCOMES (PSOs): Towards the end of the program, the students will be able to:

- Understand concepts in basic and applied microbiology.
- Acknowledge the role of microorganisms in medicine, health, food, industry, waste management, environment monitoring, agriculture and genetic manipulation
- Apply theoretical knowledge to conceptualize experiments in laboratory setting and learn to handle microorganisms
- Use relevant tools, equipment and instruments in laboratory
- Develop observational and analytical skills necessary for interpretation of experiments and projects
- Exhibit critical thinking, problem solving skills⁴³ and interdisciplinary approach in addressing microbiological problems
- Effectively communicate scientific information with clarity and precision
- Demonstrate ethical awareness and professional responsibility
- Demonstrate the ability to engage in self directed learning and collaborative team work

BACHELOR OF SCIENCE (PHYSICS)

PROGRAMME SPECIFIC OUTCOMES (PSOs): The curriculum motivates and encourages students to:

- Understand basic concepts of Physics.
- Understand the core areas of Physics, including mechanics, thermodynamics, quantum mechanics and electronics at a level compatible with graduate programs.
- Be able to analyze and interpret quantitative results, both in the core areas of Physics and interdisciplinary areas.
- Be able to use contemporary experimental apparatus and analysis tools to acquire, analyze and interpret Scientific data.
- Be able to apply the principles of Physics to solve new and unfamiliar problems.
- Be able to effectively communicate Scientific results.

B.Sc. COMPUTER SCIENCE

Three year graduate course (Choice Based Credit System and Grading System) was introduced by University of Mumbai in the academic year 2016-17. This course enables the student to make a [career in Software industry](#), pursue higher education and undertake research work.

Eligibility Criteria: A candidate for being eligible for admission to the three years integrated course leading to the degree of Bachelor of Science (B.SC. Computer Science) must have passed Higher Secondary School Certificate Examination (Std. XII) in Science stream conducted by the Maharashtra State Board of Secondary and Higher Secondary Education with [Mathematics and Statistics](#) as one of the Subjects or its equivalent. OUT OF 48 SEATS, 24 ARE RESERVED FOR MINORITY AND INHOUSE STUDENTS

The syllabus of Semester I & II has six core courses of Computer Science and one Ability Enhancement Course. All core subjects have theory as well as practical. The syllabus design for all semesters encompasses more advanced and specialized courses of Computer Science. Students pursuing this course will get a very strong foundation and exposure to basics, advanced and emerging trends in the subject.

NOTE: It is not essential for a student opting for B.Sc. Computer Science to have opted for Computer Science subject in XI & XII. Candidate should have passed H.S.C in Science stream with Mathematics and Statistics as one of the subject or its equivalent to be eligible to apply.

Faculty of Science

NEP Credit Structure for Computer Science

Level	Sem	Major		Minor	OE	VSC	SEC	AEC	IKS	VEC	OJT/FP /RP/CC /CEP	Cumulative Credits	
		DSC	DSE										
4.5	I	6		4	2+2		2	2	2	2		22	UG Certificate Cumulative Credit:44
	II	6		4	2+2	2		2		2	2	22	
Exit Option: Award of UG Certificate in Major with 40 -44 Credits and an Additional 4 Credits Core NSQF Course / Internship OR Continue with Major and Minor													
5	III	10		4	2		2	2			2	22	UG Diploma Cumulative Credit:88
	IV	10		4	2		2	2			2	22	
Exit Option: Award of UG Diploma in Major and Minor with 80-88 Credits and an Additional 4 Credits Core NSQF Course /Internship OR Continue with Major and Minor													
5.5	V	10	4	2		2	2				2	22	UG Degree Cumulative Credit:132
	VI	10	4	2			2				2+2	22	
Total													
		52	8	20	12	4	10	8	2	4	12	132	

Faculty of Science

FYBSc (Computer Science)

Course	Sem	Course Title
Major	I	Programming with Python
		Digital Systems
	II	Design and Analysis of Algorithm
		Object Oriented Programming
Minor	I	Descriptive Statistics with R Programming
	II	Application Development in Python
Vocational Skill Course and Skill Enhancement Course	I	Linux
	II	Web Technologies
AEC	I	Communication Skills
	II	Creative Content Writing
VEC	I	Green Technologies
	II	Human Values Development
IKS	I	Indian Constitution and Culture

Faculty of Science

FYBSc (Computer Science)

Open Elective Course

Semester I	Semester II
Basics of HRM – I	Basics of HRM – II
Financial Literacy	Indian Financial Systems
E-Commerce and Digital Marketing	Auditing – I
Know your Society (I) ⁴⁸	Cyber law and IPR – I
Personal Effectiveness I	Welfare State and Society (II)
Short Film Making & Editing Course	Personal Effectiveness II
	The Art of Reel Making

BACHELOR OF SCIENCE (COMPUTER SCIENCE)

PROGRAMME SPECIFIC OUTCOMES (PSOs): At the end of the programme, the students will be able to :

- Become a part of a pool of Technologically savvy, theoretically strong, innovatively skilled and ethically responsible generation of Computer Science professionals.
- Evaluate his/her computer science domain specific skills and also to meet industry expectations.
- Develop capabilities to design formulations of computing models and its applications in diverse areas.
- Effectively utilize the knowledge of computing principles and mathematics theory to develop sustainable solutions to current and future computing problems.
- Perform innovations in the subject as the choice of the Project topic.

Faculty of Commerce

NEP Credit Structure for Commerce

Level	Sem	Major		Minor	OE	VSC	SEC	AEC	IKS	VEC	OJT/FP /RP/CC /CEP	Cumulative Credits	
4.5	I	DSC 4	DSE -	4	2+2	2	2	2	2	2	-	22	UG Certificate Cumulative Credit:44
	II	4	-	4	2+2	2	2	2	-	2	2-CC	22	
Exit Option: Award of UG Certificate in Major with 40 -44 Credits and an Additional 4 Credits Core NSQF Course / Internship OR Continue with Major and Minor													
5	III	8	-	4	2	-	2	2	-	-	2-CC 2-FP	22	UG Diploma Cumulative Credit:88
	IV	8	-	4	2	2	-	2	-	-	2-CEP 2-CC	22	
Exit Option: Award of UG Diploma in Major and Minor with 80-88 Credits and an Additional 4 Credits Core NSQF Course / Internship OR Continue with Major and Minor													
5.5	V	12	4	2	-	2	-	-	-	-	2-FP	22	UG Degree Cumulative Credit:132
	VI	12	4	2	-	2	-	-	-	-	2-OJT	22	
Total		48	8	20	12	10	6	8	2	4	14	132	

Faculty of Commerce

FYBCom

Course	Sem	Course Title
Major	I	Accounting and Financial Management I
		Commerce I-Business & Entrepreneurship
	II	Accounting and Financial Management II
		Commerce II-Introduction to Service Sector
Minor	I	Managerial Economics-I
		51 Managerial Economics-II
	II	
Vocational Skill Course and Skill Enhancement Course	I	Excel
		Introduction to Digital Marketing-I
	II	Advanced Excel
		Introduction to Digital Marketing-II

BACHELOR OF COMMERCE

PROGRAMME OUTCOMES (POs): Towards the end of the program, the students will be able

to:

- Understand and apply Commerce knowledge and skills.
- Work in digitalised environment.
- Get motivated to involve in entrepreneurial activities.
- Exercise critical thinking and reasoning in problem solving activities.
- Pursue higher education/ get ready for employment.
- Develop self-confidence and attitude for lifelong learning.

52



Ability Enhancement course, Value Education course and IKS for
FYBSc, FYBCom and FYBA

Course	Semester I	Semester II
AEC	Communication Skill—I (English)	Communication Skill—II (English)
VEC	Good Citizenship - I	Good Citizenship - II
IKS	Indian Theatre	

BACHELOR OF COMMERCE(MANAGEMENT STUDIES) PROGRAMME

HIGHLIGHTS OF THE B.M.S. PROGRAMME

- Teaching Methodology: Apart from chalk & talk method, students are taught USING Powerpoint presentations, Live projects, frequent references to Print media, Role plays, case studies & demonstrations .
- Project work: The syllabus includes most innovative topics for project work in areas of Marketing, HR, Financial Management, Economics, General Management & others which deal with visits to various organisations for collection of data.
- Industrial Visits & Educational Tours: To enable the students to get firsthand knowledge on the various business processes, industrial visits are arranged in each semester, Visits have been arranged to Parle-G, Mahananda Dairy, Aarey Milk, Volvo automobiles, MAPRO Foods Product, Mala's Foods Product, Neel Kamal Plastics, Bombay Rayon Limited, Exide Batteries, Brinton Carpets, Alok Industries, Reliance Power Plant₅₄, Alok Yarns, Jayant Prints & Packs, Sundaram Limited, Pune Stock Exchange, Kohinoor Business School.
- Guest Lectures: Guest lectures by experts from esteemed institutes & industry are arranged to enhance subject knowledge of students & to make them aware of latest developments in Management.
- BMS Activities: Various co-curricular activities are frequently organized by BMS students class wise such as Quiz rounds, skit, paper presentations etc. These activities create confidence in the students & enhance their communication skills & interpersonal skills. The thrust is on application of knowledge & overall personality development.

Faculty of Commerce(Management Studies)

NEP Credit Structure for Management Studies

Level	Sem	Major		Minor	OE	VSC	SEC	AEC	IKS	VEC	OJT/FP /RP/CC /CEP	Cumulative Credits	
		Mandatory	Elective										
4.5	I	6	-	2	2 + 2	2	2	2	2	2	-	22	UG Certificate Cumulative Credit:44
	II	6	-	2	2 + 2	2	2	2	-	2	2	22	
Exit Option: Award of UG Certificate in Major with 40 -44 Credits and an Additional 4 Credits Core NSQF Course/ Internship OR Continue with Major and Minor													
5	III	8	-	2 + 2	2	2	-	2	-	-	4	22	UG Diploma Cumulative Credit:88
	IV	8	-	2 + 2	2	2	2	2	-	-	4	22	
Exit Option: Award of UG Diploma in Major and Minor with 80-88 Credits and an Additional 4 Credits Core NSQF Course/ Internship OR Continue with Major and Minor													
5.5	V	10	4 (F) Or 4 (M)	2 + 2 (F) Or 2 + 2 (M)	-	2	-	-	-	-	2	22	UG Degree Cumulative Credit:132
	VI	10	4 (F) Or 4 (M)	2 + 2 (F) Or 2 + 2 (M)	-	-	-	-	-	-	4	22	
Total		44 + 4	8	20	12	10	6	8	2	4	14	132	

Faculty of Commerce (Management Studies)

FYBCom. (Management Studies)

Course	Sem	Course Title
Major	I	Principles of Management
		Fundamentals of Accounting
	II	Foundation of Human Skill
		Business Economics
Minor	I	Introduction to Marketing
	II	Introduction to Finance
Vocational Skill Course and Skill Enhancement Course	I	Industrial Application of Business Law
		Dynamics of Effective Leadership
	II	Cyber Law & IPR –I
		Sustainable Business Practices
AEC	I	Effective Communication Skills - I
	II	Effective Communication Skills - II
VEC	I	Elements of Business Ethics
	II	Corporate Social Responsibility
IKS	I	Ancient Indian Management- Thoughts and Practices

BACHELOR OF COMMERCE(MANAGEMENT STUDIES) PROGRAMME

PROGRAMME OUTCOMES (POs): Towards the end of the program, the students will be able:

- To perform a thorough strategic analysis of an organization and an Industry by understanding internal and external business environment.
- To develop a knowledge base through conceptual learning by mode of interaction, presentations, projects, industrial visits and practical training.
- To build a managerial personality in a holistic manner with an all-round development of skills of leadership, pro-active decision-making and facing challenging situations.
- To take up competitive examinations and higher studies such as MMS, MBA in the field of specialization like Marketing, Finance, HR etc.
- To enhance interpersonal communication by overcoming their weaknesses.
- To promote an industrial outlook and bridge the gap between theory and practical applications to meet the industrial requirements.

BACHELOR OF COMMERCE (ACCOUNTING AND FINANCE)

PROGRAM

PROGRAMME OUTCOMES (POs): Towards the end of the program, the students will be able:

- To provide strong emphasis on developing analytical skills and to offer a solid grounding & professional competence in all aspects of Commerce particularly corporate accounting & costing, direct and indirect taxation.
- To provide innovative solutions to problems, apply research skills to business challenges particularly financial management.
- To tabulate the basic differences between the generally accepted Accounting Standards (GMP) in the United States and the International Financial Reporting Standards (IFRS).
- To acquire knowledge in the field of accounting, taxation, auditing, risk management, financial accounting, taxation, managerial economics, business law and business communication.
- To take up competitive examinations and higher studies such as CA/CMA/CS.
- To enhance interpersonal communication by overcoming their weaknesses.

HIGHLIGHTS OF THE B.A.F. PROGRAMME

- Teaching Methodology: Power point presentations, live projects, role plays, case studies and demonstrations apart from chalk and talk method.
- Project work: The programme embodies innovative project topics in areas of financial management and economics.
- Industrial Visits & Educational Tours: These are organized in every semester to organizations such as Bombay Stock Exchange, Pune Stock Exchange, SEBI, RBI, NIA, Micro finance companies.
- Guest Lectures: Experts are invited from the industry and various institutes to address the students to enhance their subject knowledge and to keep them abreast of the latest developments in the field.
- BAF Activities: In order to enhance students' confidence, communication skills and interpersonal skills, various co-curricular activities such as business plans, short film making, skits, paper presentations etc. are organized.

Faculty of Commerce(Accounting and Finance)

NEP Credit Structure for Accounting and Finance

Level	Sem	Major		Minor	OE	VSC	SEC	AEC	IKS	VEC	OJT/FP /RP/CC /CEP	Cumulative Credits	
		Mandatory	Elective										
4.5	I	4 + 2	-	2	2 + 2	2	2	2	2	2	-	22	UG Certificate Cumulative Credit:44
	II	4 + 2	-	2	2 + 2	2	2	2	-	2	2)	22	
Exit Option: Award of UG Certificate in Major with 40 -44 Credits and an Additional 4 Credits Core NSQF Course/ Internship OR Continue with Major and Minor													
5	III	4 + 4	-	2 + 2	2	2	-	2	-	-	4	22	UG Diploma Cumulative Credit:88
	IV	4 + 4	-	2 + 2	2	2 ⁵⁹	2	2	-	-	2	22	
Exit Option: Award of UG Diploma in Major and Minor with 80-88 Credits and an Additional 4 Credits Core NSQF Course / Internship OR Continue with Major and Minor													
5.5	V	4 + 4 + 2 (IKS)	4	2 + 2	-	2	-	-	-	-	2	22	UG Degree Cumulative Credit:132
	VI	4 + 4 + 2	4	2 + 2	-	-	-	-	-	-	4	22	
	Total	44 + 4	8	20	12	10	6	8	2	4	14	132	

Faculty of Commerce (Accounting and Finance)

FYBCom. (Accounting and Finance)

Course	Sem	Course Title	
Major	I	Financial Accounting I	
		Cost Accounting - I	
	II	Financial Accounting II	
		Direct Taxation - I	
	Minor	I	Business Economics - I
		II	Commerce - I
Vocational Skill Course and Skill Enhancement Course		I	IT in Accountancy – I
	Financial management – I		
	II	IT in Accountancy – II	
		Financial management – II	
AEC	I	Effective Communication Skills - I	
	II	Effective Communication Skills - II	
VEC	I	Professional Ethics	
	II	Code of Conduct in Industry	
IKS	I	Ancient Indian Management- Thoughts and Practices	

Faculty of Commerce

Open Electives for FYBCom, FYBCom. (Accounting and Finance), FYBCom. (Management Studies)

Semester I	Semester II
Web Designing	IT Platforms tools and practices (2)-CS
Data Analytics using excel (1)-CS	Structured Query Language (2)-CS
Chemistry in everyday life – Food Chemistry	Chemistry in everyday life –Chemistry of Cosmetics and Grooming Products
Descriptive statistics I	Descriptive statistics II
Nursery development and Garden operation	Mushroom cultivation
Know your Society (I)	Welfare State and Society (II)
Short Film Making & Editing Course	The Art of Reel Making
Personal Effectiveness I	Personal Effectiveness II

List of CC offered to the First year students of all streams

- **NSS**
- **NCC (subject to the availability of seats)**
- **Yoga**
- **Cultural activity**
- **Sports**
- **Department specific CC**

Rules for admission

While taking admission to F.Y.B.A./B.Sc./B.Com./B.M.S./B.A.F./B.Sc (Computer Science) class, students shall submit the following documents ONLINE:

- Duly completed Admission form with scanned passport size colour Photograph. This photograph will be used for Identity Card.
- Copy of H.S.C marksheet.
- Copy of College Leaving Certificate.
- Copy of Online enrollment form of the University of Mumbai.

For Online registration, the link is available on the College Website.

STUDENTS COMING FROM OTHER STATES (DEGREE COLLEGE)

Eligibility procedure for students coming from other states or those who have passed examination other than those conducted by the Maharashtra State Board of Secondary and Higher Secondary Education will be done by the College Office. Students will have to submit all the documents required at that time failing which College will not be responsible for the eligibility confirmation.

MASTERS DEGREE



M. COM. (ADVANCE ACCOUNTANCY) PROGRAMME

2 Years Post Graduate Course Affiliated to University of Mumbai SEATS: 60

HIGHLIGHTS OF M.COM. PROGRAMME

1. M.Com as per NEP 2020.
2. Inter-disciplinary approach.
3. Flexible and holistic learning and assessment.
4. Higher Employability skills development with Internship

HIGHLIGHTS OF M.COM. PROGRAMME IN ROYAL COLLEGE

1. Excellent Faculty with 20+ years of experience.
2. Students secure “ 10 pointers” with “good grades”⁶⁵
3. Exceptional Mentor mentee relationship among teacher and learner.
4. Innovative Pedagogies used.
5. Research Aptitude building.
6. Insights into real life corporate working by developing problem solving strategies
7. Exposure to work with accounting Software at advanced level.
8. Higher level of financial literacy among learners.

M. COM. (ADVANCE ACCOUNTANCY) PROGRAMME

PROGRAMME OUTCOMES (POs): Towards the end of the program, the students will be able to

- Understand and apply advanced commerce knowledge and skills.
- Understand the economics of management and ethics of business.
- Get motivated to involve in entrepreneurial activities.
- Exercise critical thinking and reasoning in problem solving activities.
- Get ready for employment.
- Develop self-confidence and attitude for lifelong learning.

CERTIFICATE COURSE IN GERMAN

- In the year 2018-2019, our college introduced **1 year Certificate Course** in German conducted by University of Mumbai. **50 students** can be enrolled for this course. Offline Lectures are conducted by faculty from **Mumbai University** every Sunday for **3 hours**.
- **Eligibility criteria for Enrollment:** S.S.C. Age: No bar Course duration: 1 Year
- This course is open for all i.e. students studying in Royal College as well as residents of Mira Road and neighbouring areas.

CERTIFICATE COURSES

- The college conducts a number of certificate courses with a view to impart additional knowledge and skills, so as to create opportunities for employment/self-employment.
- Some courses have been designed to develop and enhance global competencies. These courses can be done by the students along with their regular studies.

Below is the list of certificate courses conducted over the years :

LIST OF CERTIFICATE COURSES

1. Introduction to Biostatistics course
2. Basics/Advance Course of Photoshop
3. Origami and Mathematics
4. Digital Marketing
5. Urban Farming
6. Research Methodology
7. Basic Accountancy
8. Research Methodology and Advanced Laboratory Techniques
9. Bird Study

10. Fundamentals of Book Keeping and Accountancy
11. Soft Skill training
12. Operation Research
13. Food and Fruit Preservation
14. Certificate Course on Spoken English
15. Product Designing
16. Basic Astronomy
17. Web Designing

EXAMINATION RULES & REGULATIONS FOR DEGREE COLLEGE

Examination rules are as laid down by the University of Mumbai/College. Relevant information on examination rules will be displayed on the students' notice board as and when we receive the University circular.

Under NEP the examination will be based on the 60-40 pattern for the first year students. Semester end exams will carry 60% of the total marks and internal exams will carry 40% of the total marks.

KNOWLEDGE RESOURCE CENTRE (LIBRARY)

Camaruddin Poonawalla Knowledge Resource Centre (Library) is hub of knowledge, located on the 2nd Floor of the College building. The aim is to facilitate convenient and user friendly access to current, global and relevant information to the students. We at Royal College look forward to encourage and promote reading habits in our students' through various library activities.

FACILITIES

- Online access to question papers of examinations held in the last four years.
- Home issue of Books and Periodicals.
- Library Blog for the students to update about library activities.
- Reprography Facility/Printout facility.
- Library Wizard Card for first three merit students in each class.
- Book Bank : An Extension of Library at the Departmental level.

ACTIVITIES

- Library Orientation for First Year students.
- Annual Book Exhibition cum Sale.
- Book Review Competition.
- Library Wizard Award.
- Display of books on days of National importance as well as subject special book displays.
- Visit to Asiatic Library, Museum.
- Poetry Reading Session in Collaboration with the Literary Circle of the college.

Our college Library has created Web Blog which has current information regarding Library and e-resources of the library for the users. Access to Scanned Question papers of previous four academic years, syllabus are made available through this blog. Blog also has links to important websites like:

- UPSC, MPSC, SSC,UGC-NET
- Databases like DOAJ, National Digital Library of India, National portal of India
- For Research websites like E-Shodhganga, Shodhgangotri,
- Links of Online newspapers.
- Access to Web OPAC (Online Reissue & searching of library books) is provided from this web blog.

ABOUT KNOWLEDGE RESOURCE CENTRE (LIBRARY)

Royal College Digital Library: Royal College Digital Library aims at sharing information among the students from the sources which are available in Open Access through various National and International Online Resources. It also works as archive for College News letters.



Link:<https://royalcollegedigitallibrary.blogspot.com/p/about-digital-library.html>

CAMARUDDIN POONAWALLA KNOWLEDGE RESOURCE CENTRE

Display of Psychology Books



Display of Zoology Books



Display of Economics Book



Events by Library Literary Association:

Library Literary Association organised various activities during the academic year to encourage students for public speaking, enhance writing skills, to encourage intellectually rigorous discussion.

Content Writing Session by Prakruti Maniar:

- To offer a platform for students to learn skills related to content writing.
- To encourage to pursue content writing as their career among students.



73

Debate Competition:

- To provide a platform to students to share their thoughts on the issue of marriage recognition of homosexual couples.
- To encourage students to participate in intellectually rigorous points of discussion.
- To make the students learn the different points of views that their peers hold on a topic.

Poetry Reading Session:

- To offer a platform for students to share their literature skills through poetry.



Crossword Competition:

- Promoting Cognitive Agility and Language Skills
- Foster a Sense of Community and Collaboration



Elocution Competition:

- To offer a platform for students to share stories related to their college life.
- To encourage public speaking among students.



ENRICHMENT ACTIVITIES

A wide range of co-curricular & extra-curricular activities, designed and envisaged to widen the mental horizon of students, develop creativity & skills and extend their range of interest in life around them, are organized through :

- Arts Association
- Association of Royal Microbiologist
- Chemical Association
- Commerce Association
- Literary Association
- Fine Arts & Cultural Club
- Hiking Club

- Info. T. Club
- Maths Club
- National Service Scheme (N.S.S.)
- National Cadet Corps (N.C.C.-3 Maharashtra Battalion)
- The Green Club(Nisarg)
- Royal Physics Club
- Sports and Gymkhana
- Students' Council

75



COUNSELLING CELL

Students undergo a lot of stress these days & in order to help them to solve their problems, the college has set up a Counselling cell headed by a professional Counsellor who is available in the College Campus.

MENTORSHIP

The College designates a faculty member as mentor for a small group of students admitted to F.Y.B.A./B.Sc./B.Com./ B.M.S. /B.A.F.⁷⁶ class. The mentor meets the students in a group and **interacts with them about their academic and personal difficulties and if required counsels them.** A student can access his/her mentor anytime when there is a difficulty.

C. G. POONAWALLA YOG SADHANA KENDRA

A full-fledged Yoga Centre of our college caters to the **physical and mental well-being** & spiritual growth of students. The activities of the centre are managed by professionals from Yoga Institute, Santacruz. It is also open to the general public at a **very nominal rate**. We have started **HAPPY Sunday Club for Senior Citizens** (above 60 years of age) free of cost. Under HAPPY SUNDAY Club Senior Citizens Meet at the Yoga Centre on last Sunday of every month. They showcase their talents in Cooking, Acting, Singing, Games etc. apart from doing yoga asans. Occasionally they are taken for outdoor trips to Resorts, National Park etc



Student Development Programme



To help students to develop an all round personality, the following programs are conducted every year.

- **Commando Training** for boys and girls conducted by Indian Military Training Centre, Pune.
- **Self-defense Course** for girls conducted by a professional Taekwondo Academy.
- **Professional Coaching** for Lawn Tennis & Basketball available on campus.
- **Awareness sessions** (like “Sleep Deprivation of students’) for all degree college students.
- **Annual blood check-up** for first year students.

Royal College Alumni Welfare Association

The Royal College Alumni Welfare Association a registered body incorporated under the Society Registration Act, is a vibrant community of former students who are deeply committed to contributing to the upliftment and growth of both the institution and its current learners. With a shared sense of pride and gratitude towards their alma mater, these alumni are dedicated to giving back and supporting the development of the institution that played a crucial role in shaping their lives. Through various initiatives, mentorship programs, entrepreneurship guidance talk, networking college events, and career guidance sessions, the alumni association works tirelessly to create opportunities for current students, empower them to achieve their goals, and foster a sense of community and belonging within the institution. Alumni looks forward to grow this community by encouraging ideation and association with former students. Their unwavering support and active engagement create a strong bond between the institution, its alumni, and its learners, ensuring excellence and success.



Alumni activities includes Counselling and career guidance and judges for events

Field trip / Industrial Visits (IV)



**Psychology Department
Visit to Rehab Centre**



**IV to Go Cheese Factory
TYBMS & TYBAF**



IV to NITCO (SYBAF)



IV to Siyaram Mills (SYBMS)

80



Industrial Visit to TMC

Placement Cell

The Placement and Training Committee of Royal College organises and contacts the companies and invites them for campus recruitment and arranges training programmes. They are also responsible for hospitality of the company and conduct the placement drive smoothly. They act as a link between company and students. Placement Committee also manage the database of students and gives them to company.

The objectives of Placement and Training Committee are to:

- Assist students to develop and implement successful job search strategies.
- Work with faculty members, department heads and administration to integrate career planning with academic curriculum.
- Empower students with life-long, career decision-making skills.
- Providing resources and activities to facilitate the career-planning process.
- Act as an interface among students, alumni and the employment community.
- Create awareness in the students regarding future career options.



N.C.C. (National Cadet Corps)

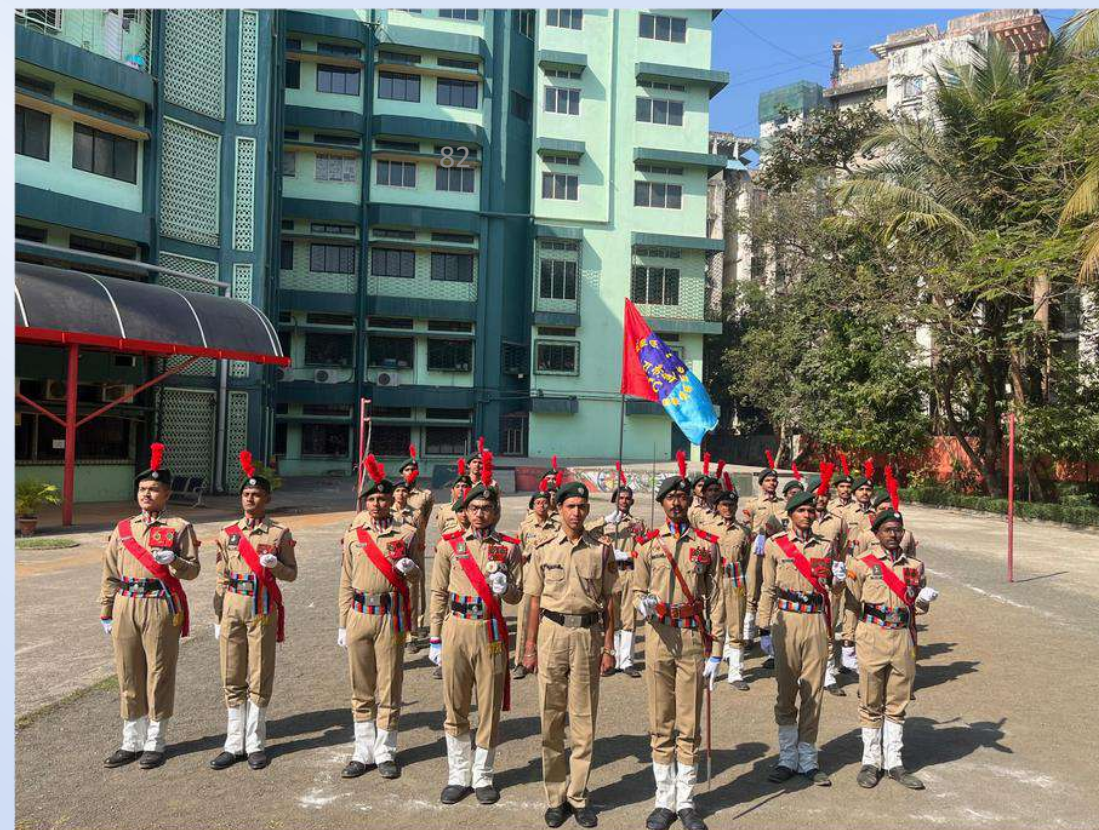

N.S.S. (National Service Scheme) Activities

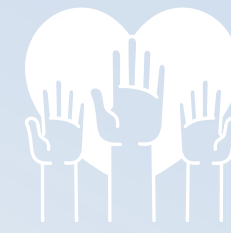

N.S.S. Camp



N.S.S. Tree Plantation

N.S.S. Gorai Beach Cleanup Drive



83



N.S.S. Rally



Staff greeting Founder Sir



Felicitation of Mr Abid Surti



Team FACC



Felicitation of retired teaching and non teaching staff

FOUNDER'S DAY CELEBRATION 2023

Founder's Day Celebration 2023



ANNUAL DAY 2023-2024

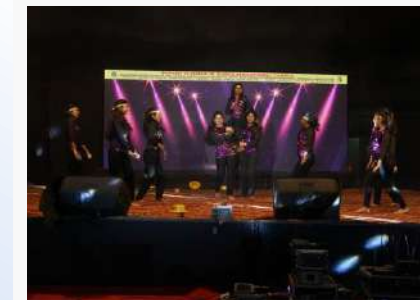

Extension & Co-Curricular Activities



Workshop on Research Methodology and IPR



Gyan Daan Activity:
Demonstration of Science experiments
to school students



Sports Day for MBMC
school students



Students teaching slum
kids

Online training on use
of technology in
education for school
teachers

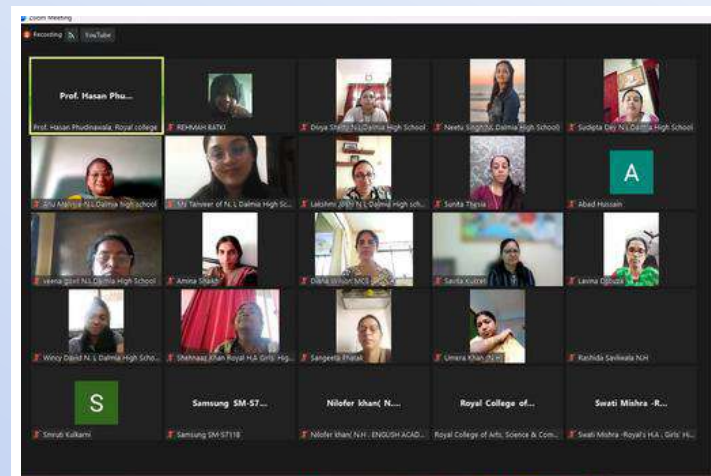

SPORTS

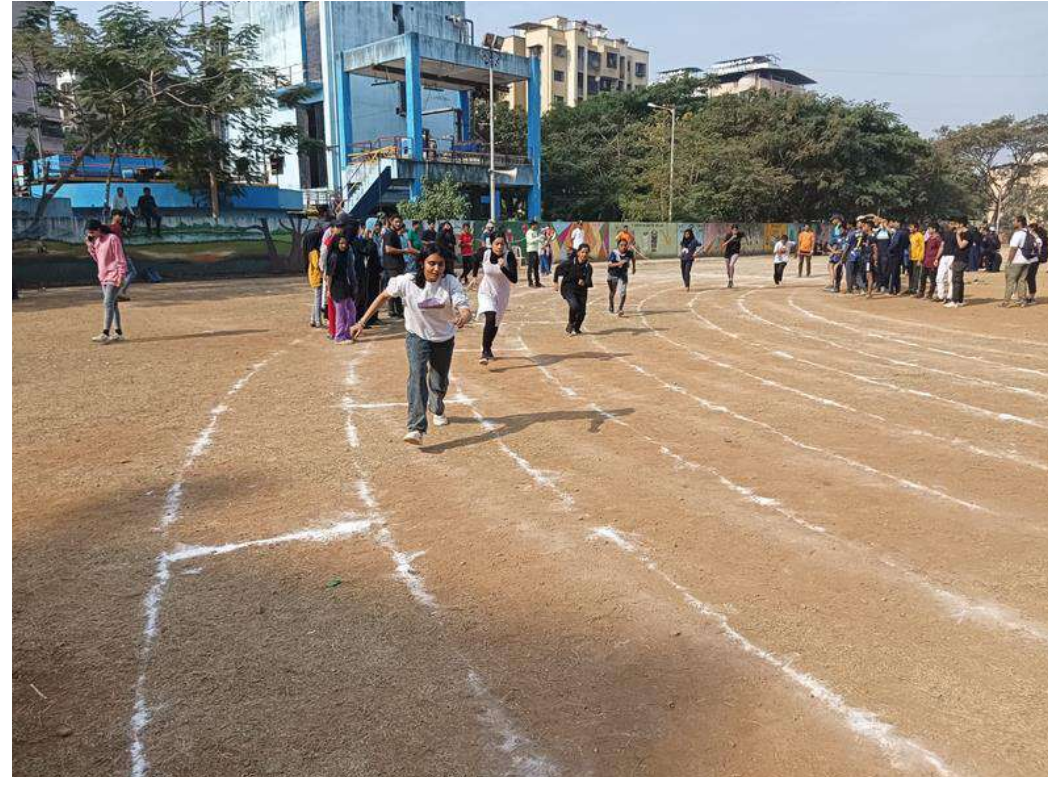

DAY 2023-2024

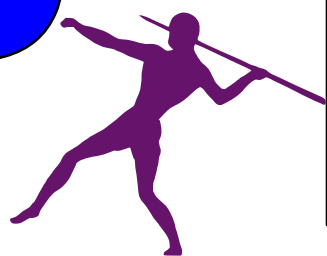

FAREWELL TO THIRD YEAR STUDENTS

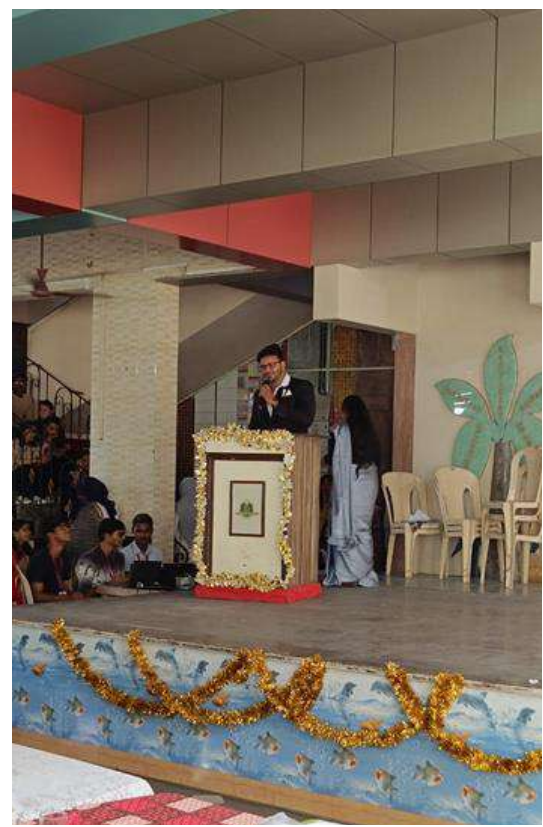

Staff and student Development committee

Staff and student development committee basically responsible for organizing development programs for students, non-teaching and teaching staff of our college. During the academic year the committee organizes various activities like talks, workshops, camps, placement drives and health related activities which can address the multiple issues of staff and students.



90

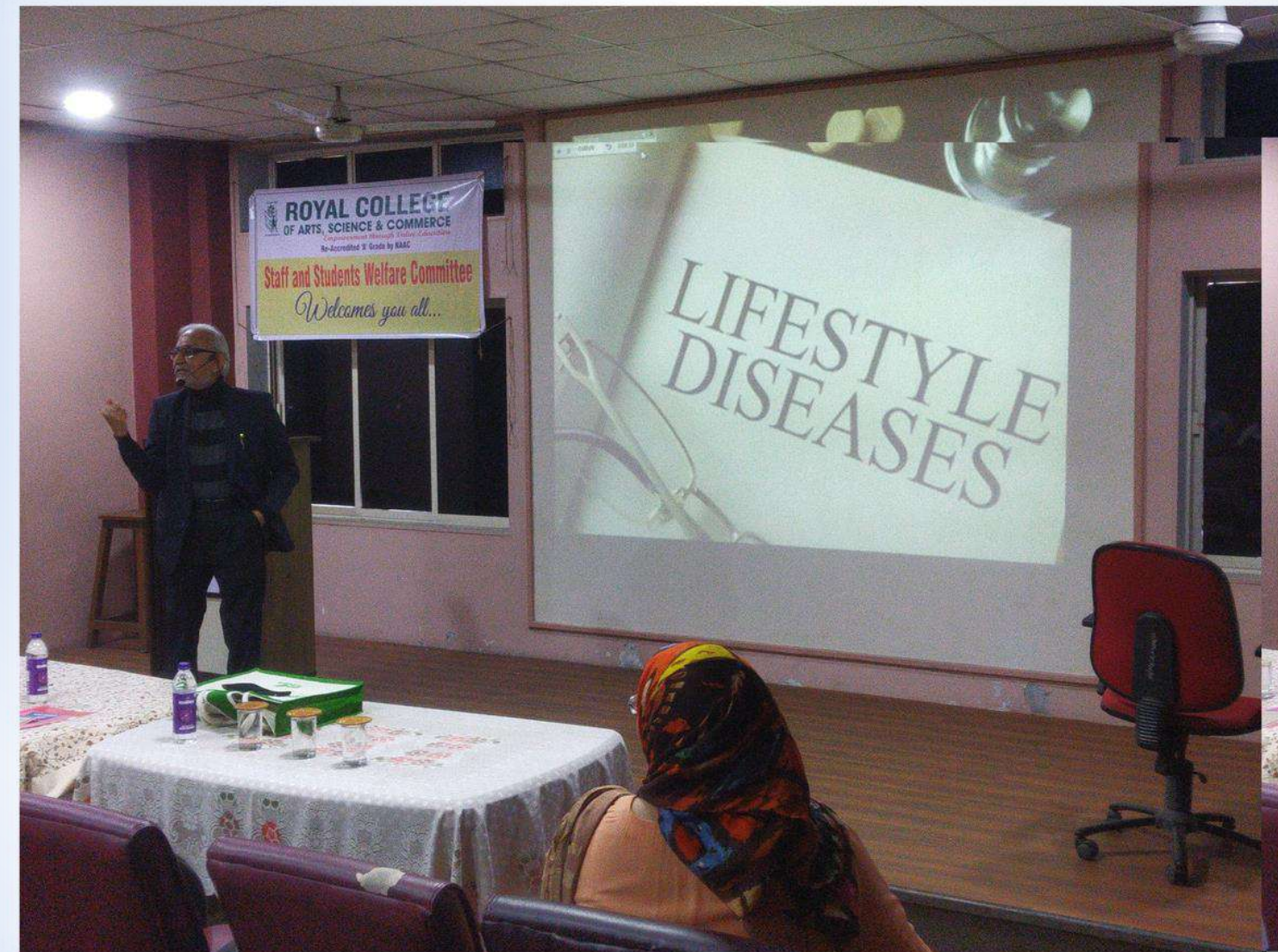

Informative session on Lifestyle diseases by Dr. Saifee Bandukwala for staff of college

Academic improvement committee

The main objective of the academic improvement committee of our college is to conduct various activities and program for academic excellence of our teaching staff. The nature of activities are basically talks, workshop and hands on training, where the teaching staff get an opportunity to learn new things mainly on topics from the domain like academic, technology and student psychology etc.

ACADEMIC SCHOLARSHIPS

Every year, the following cash prizes along with Merit Certificates are awarded to Royal College Students who are toppers in their respective classes.

<u>Class</u>	<u>Prize</u>	<u>Amount</u>
<u>T.Y.B.A.</u>		
Sociology	1st	₹5000/-
Political Science	1st	₹5000/-
Economics	1st	₹5000/-
Psychology	1st	₹5000/-
Hindi	1st	₹1500/-
<u>T.Y.B.Sc.</u>		
Chemistry	1st	₹5000/-
Physics	1st	₹5000/-
Microbiology	1st	₹5000/-
Computer Science	1st	₹5000/-
<u>T.Y.B.Com.</u>		
	1st	₹5000/- ⁹²
	2nd	₹1500/-
	3rd	₹1000/-
<u>T.Y.B.M.S.</u>	1st	₹5000/-
<u>T.Y.B.A.F.</u>	1st	₹5000/-

<u>Class</u>	<u>Prize</u>	<u>Amount</u>
(Average of both semesters for following classes)		
F.Y.B.A./F.Y.B.Com./F.Y.B.Sc.	1st	₹2000/
S.Y.B.A / S.Y.B.Com/S.Y.B.Sc.	1st	₹2000/
F.Y.B.Sc. / S.Y.B.Sc. (Computer Science)	1st	₹2000/
F.Y.B.M S. /S.Y.B.M.S.	1st	₹2000/
F.Y.B.A.F./S.Y.B.A.F.	1st	₹2000/
<u>Class</u>	<u>Prize</u>	<u>Amount</u>
XI/XII Sc.	1st	₹2000/
(Computer Science Group)	1st	₹2000/
XI/XII Sc. (Biology Group)	2nd	₹1500/
XI Commerce /XII Commerce	1st	₹2000/
	2nd	₹1500/
XI Arts /XII Arts	1st	₹2000/
	2nd	₹1500/

- Cash prize of ₹2000/- & Merit Certificate for securing the highest marks at HSC Board Examination and third year University Examination in any subject.
- Two scholarships of ₹5000/- each in the name of Asmabai Taherali is awarded to students who are first rank holders in examinations during three consecutive academic years.
- Cash Prize of ₹1000/- & Certificate for Outstanding Achievement in Sports based on Interclass, Inter-Collegiate & DSO Level Achievement.

AWARDS

1. Rukaiya Lakdawala Memorial Award for Best Outgoing Student :

Cash prize of Rs. 5000/- , Merit Certificate and Trophy will be awarded to Best Outgoing Student from each stream :

- i) Arts ii) Science iii) Commerce iv) Self Financed Stream

2. Best Class Award for Senior College

3. Best Class Award for Junior College

4. Best Athlete Award for Senior College Girls

5. Best Athlete Award for Senior College Boys

7. Best Athlete Award for Junior College Girls

8. Best Athlete Award for Junior College Boys

CERTIFICATES ARE ALSO AWARDED FOR:

- 1) 100% attendance during the academic year
- 2) Best Male participant of the academic year
- 3) Best Female participant of the academic year
- 4) The General Secretary of the Students' Council
- 5) Conscientious Vigilance Body members for their exemplary services rendered to the college.

The Green Club (Nisarg)



94





RESEARCH COMMITTEE

The research committee of our college is responsible for conducting various activities for teaching staff and students throughout the academic year. The central aim of all the programs is to motivate teachers and students to participate in research work and provide information about various opportunities and new avenues in research. The nature of program are talks, workshops, research symposium and practical training etc.

95

RESEARCH COMMITTEE



Research Presentation



Research Presentation



Students presenting in Avishkar

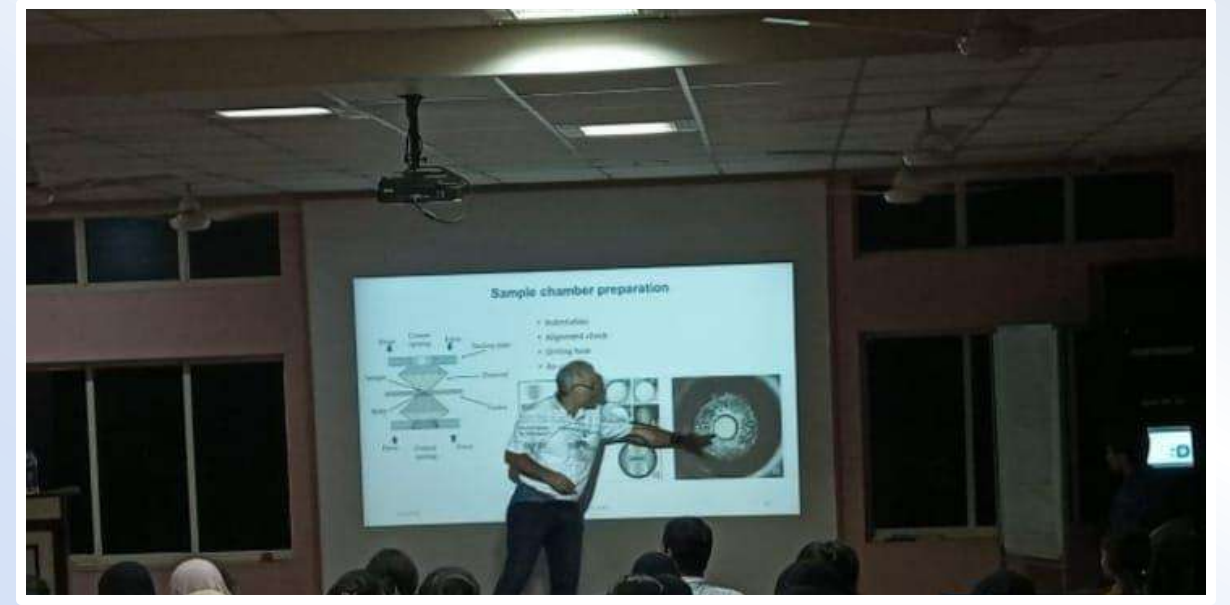

Talk by BARC Scientist Dr. K. K. Pandey



Gyan Manthan - An Inter-Collegiate fest

"Where knowledge meets fun"

Gyan Manthan is an annual inter-collegiate fest of Royal College of Arts, Science and Commerce. It is now in its 20th edition. Its motto is to 'Churn the AMRIT of Knowledge'



Bollywood mania by Degree College



Folk Dance



Teacher's Carrom competition



Mock stock by Department of BMS & BAF



Trashion event by degree college best out of waste

NATIONAL CONFERENCE

ENVIRONMENTAL SUSTAINABILITY SCIENTIFIC, ECONOMIC AND SOCIAL IMPLICATIONS

10TH FEBRUARY 2024



Guest Speakers and Dignitaries

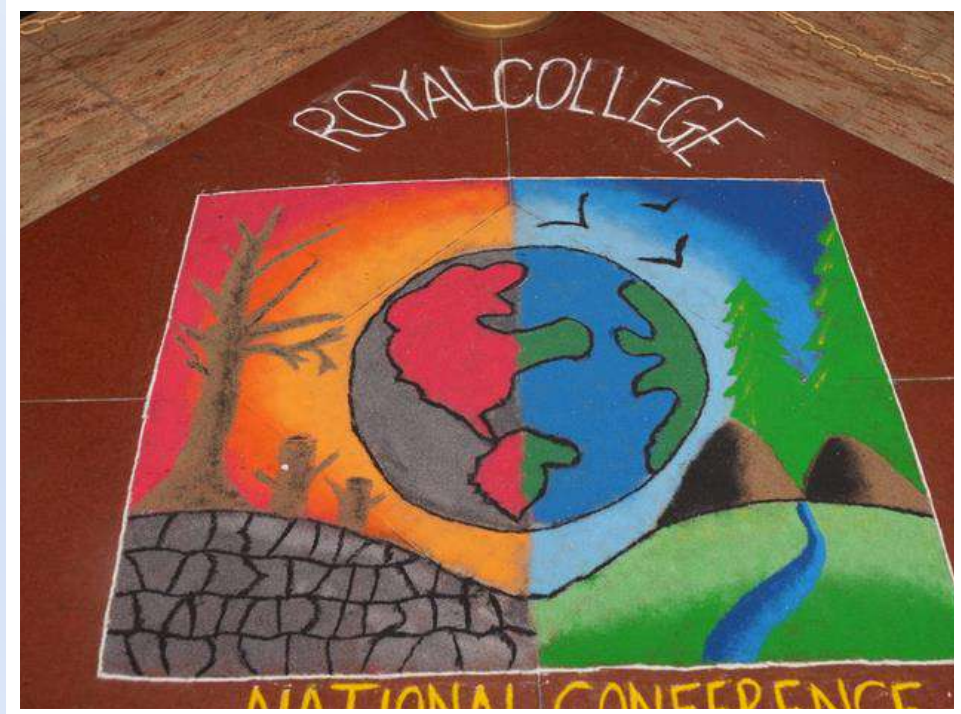

Welcome Rangoli



Inauguration Ceremony by lighting up Lamp



Municipal Commissioner (MBMC) Shri. Sanjay Shripatrao Katkar at the National Conference





FACC Painting competition



Calligraphy Competition



Presentation by Maths Club



Hike to Korigad

Student Activities



NCC Unit



International Food Day Celebrations

COMMANDO TRAINING 2023-24



CAREER KATTA

(Career and Entrepreneurship Counseling, Skill Development, Internships, Placement, etc.)

Career Katta is an initiative of Department of Higher and Technical Education, Govt of Maharashtra and in coordination with Maharashtra Information Technology Support Centre. The college conducts various activities to guide students about Career, Competitive Examinations (UPSC, MPSC, Banking, SSB, SSC, Police, LIC, etc.), Entrepreneurship, Skill Development; Credit Earnings under new CBCS and NEP Curriculum Framework, Internship and Placement Opportunities, etc.

Eligibility to Join: Any student admitted for any regular course in the college or college alumni referred by College Coordinator. Registration Fees: One Time Rs. 365 for Three-year degree period (Rs. 0.36 per day), which will be reimbursed in the form of subsidy on examination charges of CBCS. It including free access to all the activities, courses, State Level Competitive Exams, etc.

How to Register: Download the MITSC application from Google Play Store and pay fees using any online payment mode

College Code: C--33752

101

Contact:

For more details visit college webpage: <https://royalcollegemiraroad.edu.in/>

or

Contact Coordinator: Dr Raju Kurian

or

Career Katta Helpline: 75076 52555

"A HUNDRED TIMES EVERY DAY I REMIND MYSELF THAT MY INNER AND OUTER LIFE DEPEND ON THE LABOURS OF OTHER MEN, LIVING AND DEAD, AND THAT I MUST EXERT MYSELF IN ORDER TO GIVE IN THE SAME MEASURE AS I HAVE RECEIVED AND AM STILL RECEIVING."

- Albert Einstein



- **Fatema Alibader Welfare Centre (1984)**
- **Royal Higher Education Society (1986)**
- **Royal College of Arts, Science & Commerce (1989)**
- **Royal's H.A. Girls' High School (English Medium) (1995)**
- **Royal's Y.F. Zaveri Girl's Urdu School (2001)**
- **Taher Adamali College of of Education and Research for Women (2012)**

Ismail M. Kanga Educational Campus, Penkarpada, Mira Road (E), Dist. Thane - 401 107.

Principal's Office Tel. : 9167550100 • Email : trams786@yahoo.com

Adm. Office Tel. : 9136312913 / 9167559524 • Email : royalcollege_office@yahoo.com

Website: www.royalcollegemiraroad.edu.in